

AHU

AIR HANDLER

AHU 800

**VERY
QUIET**

 **MADE IN CANADA**



The AHU Air Handler pairs perfectly with any hot water heat source to allow for warm air heating throughout the building. With six position mounting and return air openings on the left, right, and bottom of the unit, the AHU - 800 has the flexibility to accommodate a wide range of application requirements.

Available on the
 **App Store**

ANDROID APP ON
 **Google play**

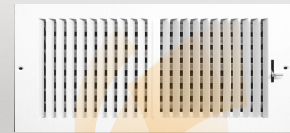

- Whisper quiet blower operation
- Up to 68,000 BTU at 180°F
- High efficiency ECM motor with centrifugal fan
- Use with any hot water appliance with pressures to 150 PSI
- High efficiency fin tube coils
- Internet capable controller
- Easy service access
- Can manage external pump
- OpenTherm control compatible
- Standard filter



**5
YEAR**
HEATING COIL
WARRANTY

**5
YEAR**
PARTS
WARRANTY

IBC INTERGAS®

AHU - 800

Technical Information

IBC INTERGAS[®]

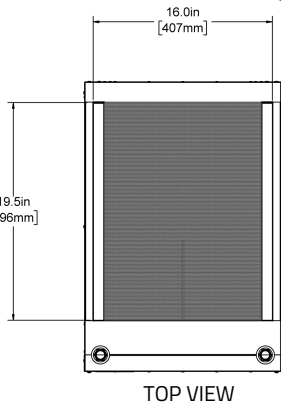
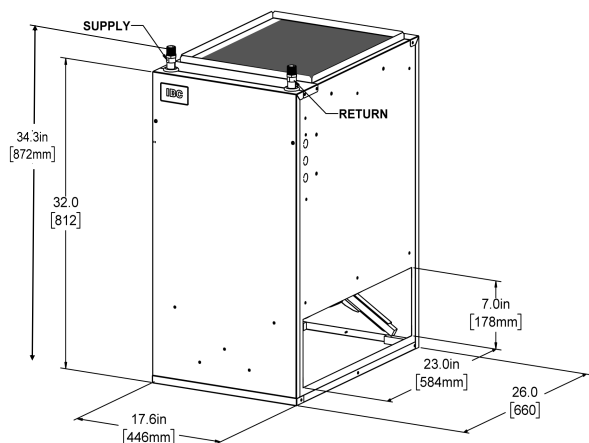

DIMENSIONS AHU 800	
Width	17.6"
Depth	26"
Height	32"

SPECIFICATIONS	AHU 800
Max. water temperature °F	195
Coil performance at 180°F (Btu/hr)	66,800
Water pipe connections	3/4"
External static pressure (wc)	0.7"
Maximum operating water pressure	150 Psi
Supply air opening width	16"
Supply air opening depth	19.5"
Left and right air opening height	7"
Left and right air opening depth	23"
Bottom return air opening width	13"
Bottom return air opening depth	23"
Max. internal current power rating 120 Volts	2.4 Amp
External pump supply 120V	5 Amp
Voltage (maximum fuse 15 Amp)	120 V
Max. air flow @ rated static pressure	1000 CFM
Filter size (Merv 8)	16 x 25 x 1

HEATING CAPACITY - Ent Dry Bulb 70°F @ 800CFM			
Entering Water Temp.	3GPM	4 GPM	5 GPM
195°F (90°C)	72.9 MBH	76.9 MBH	79.4 MBH
190°F (88°C)	65.7 MBH	70.2 MBH	73.0 MBH
180°F (82°C)	60.0 MBH	64.1 MBH	66.8 MBH
170°F (77°C)	54.4 MBH	58.1 MBH	60.5 MBH
160°F (71°C)	48.7 MBH	52.1 MBH	54.3 MBH
150°F (66°C)	43.1 MBH	46.2 MBH	48.1 MBH
140°F (60°C)	37.6 MBH	40.2 MBH	41.9 MBH
130°F (54°C)	32.0 MBH	34.3 MBH	35.8 MBH
120°F (49°C)	26.5 MBH	28.5 MBH	29.7 MBH
110°F (43°C)	21.1 MBH	22.6 MBH	23.7 MBH

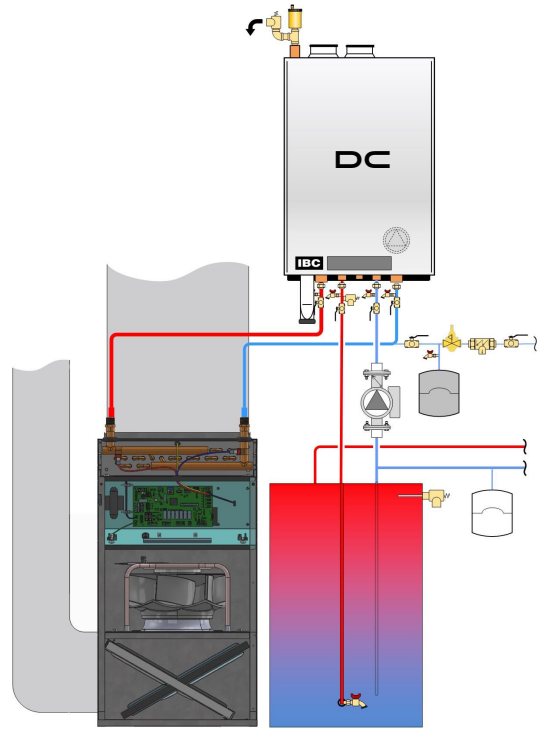
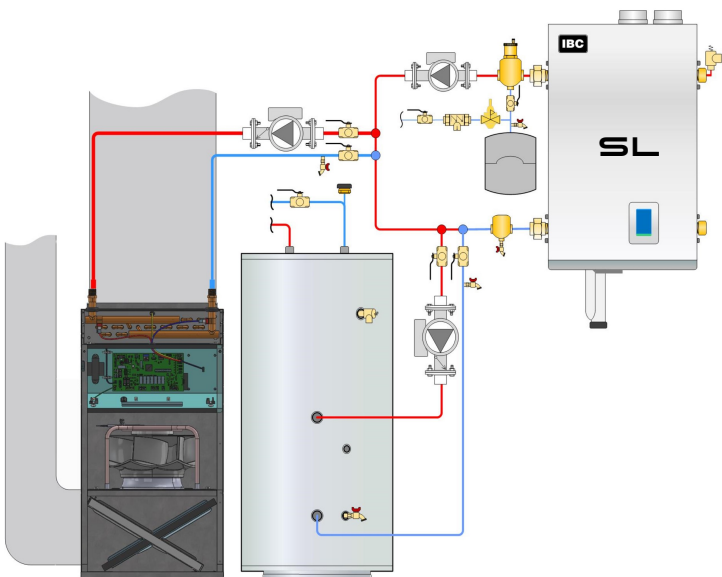

All information contained in this brochure is subject to change without notice. Due to clerical error, regulation change or product development please confirm all information with IBC INTERGAS

IBC INTERGAS - USA

1702 Taylors Lane, Cinnaminson, NJ 08077
4507 South Taylor Drive, Sheboygan, WI 53081

Tel: 856 877 0544

Fax: 856 735 5584

IBC INTERGAS - Canada

8015 North Fraser Way, Burnaby, BC V5J 5M8
Unit 5, 1455 16th Ave, Richmond Hill, ON L4B 4W5
100, 317 37th Ave NE, Calgary, AB T2E 6P6

Tel: 905 918 0113

Fax: 604 877 0295

Tel: 403 477 3208

Fax: 604 877 0295

sales@ibcboiler.com • www.ibcboiler.com

Toll Free: 1-844-HEAT IBC / 1-844-432-8422